

# CurrentGuard™ 100



## SYSTEM FEATURES

- Listed to UL 1449 3<sup>rd</sup> Edition for Type 1 and Type 2 SPD applications
- Innovative Z-Path System™ ensures equal current sharing, increased reliability and maximum performance
- Each mode protected by surge rated over-current fuse
- 200kAIC short circuit current rating allows direct bus connection without the need of an upstream over-current protection device
- Includes UL 1283 listed standard EMI/RFI filter
- All modes of protection (L-N, L-G, N-G & L-L)
- Form C contacts and audible alarm with silence button – standard
- DTS-2 compatible for “pro-active” testing
- Ultra compact steel NEMA 4 enclosure makes installation flexible
- 10-Year standard product warranty

## MODEL NUMBER SCHEME

E.g. MODEL # CG 100 - 277/480-3GY

A B

### A – SURGE RATING (Must Choose One)

40	40kA per mode
60	60kA per mode
80	80kA per mode
100	100kA per mode
150	150kA per mode
200	200kA per mode

### B – VOLTAGE (Must Choose One)

120/240-2G	120/240V, 1-Phase, 3-Wire + Ground
120/208-3GY	120/208V, 3-Phase WYE, 4-Wire + Ground
220/380-3GY	220/380V, 3-Phase WYE, 4-Wire + Ground
277/480-3GY	277/480V, 3-Phase WYE, 4-Wire + Ground
347/600-3GY	347/600V, 3-Phase WYE, 4-Wire + Ground
120/240-3GHD	120/240V, 3-Phase High-Leg DELTA, 4-Wire + Ground (B Phase must be 208V)
240-3DG	240V, 3-Phase DELTA, 3-Wire + Ground
380-3DG	380V, 3-Phase DELTA, 3-Wire + Ground
480-3DG	480V, 3-Phase DELTA, 3-Wire + Ground
600-3DG	600V, 3-Phase DELTA, 3-Wire + Ground

### STAND-ALONE OPTIONS (To Be Ordered As A Separate Item)

DTS	DTS-2 Diagnostic Test Set
-----	---------------------------

## PRODUCT SPECIFICATIONS

### General Specifications

Maximum Surge Current Capacity:	100kA per mode; 200kA per phase
Nominal Discharge Surge Current In:	20kA
Repetitive Surge Current Rating:	4,500 impulses per mode based on actual test data (using ANSI/IEEE C62.41.1-2002 C3 combo. wave)
Product Design:	Hybrid parallel design with surge rated fuse and UL 1283 EMI/RFI filter
Application:	ANSI/IEEE C62.41.1 Locations C, B & A Ideal for low exposure service entrance, distribution panels, motor control centers and branch panels
Regulatory Listing:	UL 1449 3 <sup>rd</sup> Edition Type 1 and Type 2 SPD; UL 1283
Standard Warranty:	10-Year

### Electrical Specifications

Operating Frequency:	47-63 Hz
Connection Method:	Parallel to electrical distribution system
Modes of Protection:	Discrete protection (L-N, L-G, N-G, & L-L)
Fault Rating (SCCR):	200kAIC – no upstream over-current protection device (breaker or fuse) required
Response Time:	Less than 0.5 nanoseconds
Standard Monitoring:	Status indicator lights (one per phase) Service indicator light Form C contacts (NO/NC) Audible alarm with silence button

### EMI / RFI Filter Attenuation – Mil Standard 220B

Up to 33 dB from 10 KHz to 100 MHz

# CurrentGuard™ 100

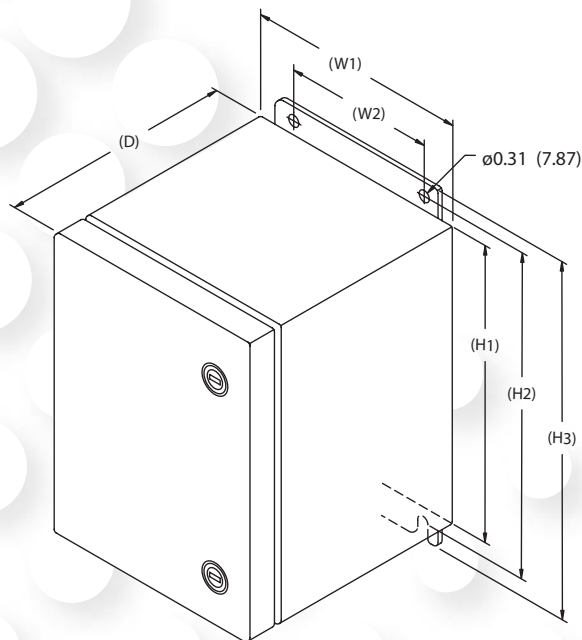

## DIMENSIONAL SPECIFICATIONS

Dim	CG100	
H1	14.00	(355.6)
H2	14.75	(374.7)
H3	15.50	(393.7)
W1	12.00	(304.8)
W2	10.00	(254.0)
D	6.20	(157.5)

All measurements in inches (mm)

## MECHANICAL SPECIFICATIONS

Enclosure Type:	Powder coated, impact-resistance steel, weather-proof NEMA 4
Installation Location:	Indoor or outdoor
Dimensions:	14"H x 12"W x 6"D
Connection Method:	Hard-wired via internal lugs #10AWG - #3 AWG
Mounting Method:	Dual mounting flanges
Operating Environment:	-40° C to +70° C (-40° F to +158° F) 5% - 95% non-condensing humidity
Weight:	40 lbs. (18.2 kg)

## CURRENTGUARD 100 PERFORMANCE DATA

Model Number	CG100-120/240-2G CG100-120/208-2G				CG100-220/380-3GY CG100-277/480-3GY				CG100-347/600-3GY				CG100-120/240-3GHD						CG100-240-3GD		CG100-380-3GD		CG100-480-3GD		CG100-600-3GD				
	System Voltage				220/380V 277/480V				347/600V				120/240V						240V		380V 480V		600V						
Protection Mode	L-N	L-G	L-L	N-G	L-N	L-G	L-L	N-G	L-N	L-G	L-L	N-G	L-N	H-N	L-G	H-G	L-L	H-L	N-G	L-G	L-L	L-G	L-L	L-G	L-L	L-G	L-L		
<b>MCOV</b>	150	150	300	150	320	320	640	320	420	420	840	420	150	320	150	320	300	470	150	320	320	550	550	750	750				
<b>B3 Ring Wave 6kV, 500A</b>	420	480	610	340	660	750	960	720	715	829	1130	670	420	759	470	640	605	800	320	750	630	1050	860	1245	1060				
<b>B3/C1 Combo Wave 6kV, 3kA</b>	642	690	1010	620	910	1068	1700	974	1250	1340	2300	1230	642	910	690	1068	1010	1400	620	940	1020	1450	1670	1960	2260				
<b>C3 Combo Wave 20kV, 10kA</b>	1040	1300	1420	1240	1490	1830	2290	1690	1910	1960	2910	1880	1040	1490	1300	1830	1420	2050	1240	1650	1680	2160	2470	2760	2950				
<b>UL 1449 3rd Edition 6kV, 3000A VPR</b>	800	800	1200	800	1200	1200	1800	1200	1500	1500	2500	1500	800	1200	800	1200	1200	1500	800	1200	1200	1800	1800	2500	2500				

All CurrentGuard™ systems measured limited voltages are peak values (±10%) measured from the zero reference point and are in compliance with test and evaluation procedures outlined in NEMA LS1-1992 (R2000), paragraphs 2.210 and 3.10.

Specifications subject to change without notice, refer to [www.currenttechnology.com](http://www.currenttechnology.com) for latest revision.



5900 Eastport Boulevard Richmond, VA 23231-4453 USA  
TEL: 804.236.3300 800.238.5000 FAX: 804.236.4047